

# TITAN

*orange county // los angeles // long beach*  
*production spec book*

**ORANGE COUNTY / OCTA**

**BUS MEDIA**

HEADLIGHT BUS POSTER DISPLAY  
TAILLIGHT BUS POSTER DISPLAY  
KING-SIZE BUS POSTER DISPLAY  
KONG-SIZE BUS POSTER DISPLAY  
HEADLINER BUS DISPLAY  
ACCESS BUS - HEADLINER & KONG BUS POSTER DISPLAY  
INTERIOR CAR CARD DISPLAY  
TAKE-ONE PAD

**LOS ANGELES / LADOT**

TAILLIGHT BUS POSTER DISPLAY  
SUPER TAILLIGHT BUS POSTER DISPLAYS - GILLIG  
TWO-SHEET TAILLIGHT BUS POSTER DISPLAYS - EZ RIDER  
TWO-SHEET TAILLIGHT BUS POSTER DISPLAYS - EZ RIDER II  
SUPER TAILLIGHT BUS POSTER DISPLAYS - EZ RIDER  
SUPER TAILLIGHT BUS POSTER DISPLAYS - EZ RIDER II  
QUEEN-SIZE BUS POSTER DISPLAY - DASH  
KING-SIZE BUS POSTER DISPLAY - COMMUTER EXPRESS  
KONG-SIZE POSTER DISPLAY - GILLIGS  
KONG-SIZE POSTER DISPLAY - NEOPLAN  
WINDOW CLING DISPLAY - COMMUTER EXPRESS  
INTERIOR CAR CARD DISPLAY  
TAKE-ONE PAD

**LONG BEACH / LBT**

TAILLIGHT BUS POSTER DISPLAY  
KING-SIZE BUS POSTER DISPLAY

ORANGE COUNTY - OCTA

**ORANGE COUNTY / OCTA**

**BUS MEDIA**

HEADLIGHT BUS POSTER DISPLAY

TAILLIGHT BUS POSTER DISPLAY

KING-SIZE BUS POSTER DISPLAY

KONG-SIZE BUS POSTER DISPLAY

HEADLINER BUS DISPLAY

ACCESS BUS - HEADLINER & KONG BUS POSTER DISPLAY

INTERIOR CAR CARD DISPLAY

TAKE-ONE PAD

## Production Spec Sheet // Headlight Bus Poster Display

### UNIT INFORMATION

<b>Finished Size</b>	15-1/4" H X 46-1/2" W
<b>Safety Copy Area</b>	14" H X 44" W
<b>Mechanical Size</b>	7-5/8" H X 23-1/4" W

### MECHANICAL(S)

<b>Scale</b>	1/2
<b>DPI @ Finished Size</b>	150 DPI
<b>DPI @ Mechanical Size</b>	300 DPI

### OVERAGE

20% overage is required for each month of posting.

### PRINT FABRICATION / FINISHING DETAILS

Copy to be produced in one (1) piece.  
Copy bleeds to edge on all four sides.

For digital processes, an overlamine is required.  
For screen printing and lithography processes, UV or conventional clear coat in compliance with product bulletin specification of substrate/ink manufacturers.

### INKS

Inks must be weatherproof/waterproof with standard UV protection, and must conform to product bulletin specifications of substrate manufacturer.

### MATERIAL / SUBSTRATE(S)

**VINYL:** Removable Transit Vinyl

### REQUIRED VINYL SUBSTRATE(S)

3M - IJ36

**GENERAL FORMULATION** - MetroMark

**FLEXCON** - BUSmark 5800  
(5100 will not be accepted)

[SEE TITAN APPROVED SUBSTRATE TABLE FOR COMPLETE LIST OF RECOMMENDED FILMS](#)

Appropriate overlaminates must be used in conjunction with the materials as listed above and/or appropriate UV clear coat.

**NOTE:** Any substitutions will require written authorization from Titan prior to production.

### ORANGE COUNTY RESTRICTIONS & REQUIREMENTS

[ALL CREATIVE MUST BE APPROVED BY OCTA PRIOR TO PRODUCTION.](#)

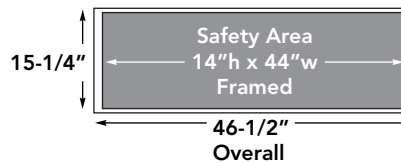

**IMPORTANT NOTE:**  
When bike rack is down the creative will be facing the street and unseen.



### SHIPPING ADDRESS

**Ship to** Outdoor Service Providers  
10601 Calle Lee, Suite 190  
Los Alamitos, CA 90720

**Phone** 714.229.0600 **Fax** 714.229.0660

**Contact** Oscar  
warehouse@collegebillboardnetwork.com

### DELIVERY

Titan Operations must receive materials 10 days prior to post date. Please include posting instructions and copy of creative with the poster shipment.

## Production Spec Sheet // Taillight Bus Poster Display

### UNIT INFORMATION

<b>Finished Size</b>	21"H X 72"W
<b>Live Copy Area</b>	17"H X 68"W
<b>Mechanical Size</b>	10-1/2"H X 36"W

### MECHANICAL(S)

<b>Scale</b>	1/2
<b>DPI @ Finished Size</b>	150 DPI
<b>DPI @ Mechanical Size</b>	300 DPI

### OVERAGE

20% overage is required for each month of posting.

### PRINT FABRICATION / FINISHING DETAILS

Copy to be produced in one (1) piece.  
Copy bleeds to edge on all four sides.

For digital processes, an overlamine is required.  
For screen printing and lithography processes, UV or conventional clear coat in compliance with product bulletin specification of substrate/ink manufacturers.

### INKS

Inks must be weatherproof/waterproof with standard UV protection, and must conform to product bulletin specifications of substrate manufacturer.

### MATERIAL / SUBSTRATE(S)

**VINYL:** Removable Transit Vinyl

### REQUIRED VINYL SUBSTRATE(S)

**3M** - IJ36

**GENERAL FORMULATION** - MetroMark

**FLEXCON** - BUSmark 5800  
(5100 will not be accepted)

**SEE TITAN APPROVED SUBSTRATE TABLE FOR COMPLETE LIST OF RECOMMENDED FILMS**

Appropriate overlaminates must be used in conjunction with the materials as listed above and/or appropriate UV clear coat.

**NOTE:** Any substitutions will require written authorization from Titan prior to production.

### ORANGE COUNTY RESTRICTIONS & REQUIREMENTS

**ALL CREATIVE MUST BE APPROVED BY OCTA PRIOR TO PRODUCTION.**

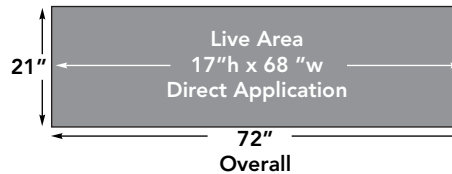

### SHIPPING ADDRESS

**Ship to** Outdoor Service Providers  
10601 Calle Lee, Suite 190  
Los Alamitos, CA 90720

**Phone** 714.229.0600 **Fax** 714.229.0660

**Contact** Oscar  
warehouse@collegebillboardnetwork.com

### DELIVERY

Titan Operations must receive materials 10 days prior to post date. Please include posting instructions and copy of creative with the poster shipment.

## Production Spec Sheet // King-Size Bus Poster Display

### UNIT INFORMATION

<b>Finished Size</b>	30"H X 144"W
<b>Live Copy Area</b>	27"H X 141"W
<b>Mechanical Size</b>	7-1/2"H X 36"W

### MECHANICAL(S)

<b>Scale</b>	1/4
<b>DPI @ Finished Size</b>	150 DPI
<b>DPI @ Mechanical Size</b>	600 DPI

### OVERAGE

20% overage is required for each month of posting.

### PRINT FABRICATION / FINISHING DETAILS

Copy to be produced in two (2) sections.  
Copy bleeds to edge on all four sides.

King sections are installed from right to left.

Registration marks are needed on top and bottom margins to ensure correct placement of sections. The left section should be 30"H x 72"H. The right section should be 30"H x 72-1/4"W - with the left overlapping the right by 1/4". The left edge of right section of overlap must be unprinted, unvarnished and unlaminated.

For digital processes, an overlamine is required.  
For screen printing and lithography processes, UV or conventional clear coat in compliance with product bulletin specification of substrate/ink manufacturers.

### INKS

Inks must be weatherproof/waterproof with standard UV protection, and must conform to product bulletin specifications of substrate manufacturer.

### MATERIAL / SUBSTRATE(S)

**VINYL:** Removable Transit Vinyl

### REQUIRED VINYL SUBSTRATE(S)

**3M** - IJ36

**GENERAL FORMULATION** - MetroMark

**FLEXCON** - BUSmark 5800  
(5100 will not be accepted)

**SEE TITAN APPROVED SUBSTRATE TABLE FOR COMPLETE LIST OF RECOMMENDED FILMS**

Appropriate overlaminates must be used in conjunction with the materials as listed above and/or appropriate UV clear coat.

**NOTE:** Any substitutions will require written authorization from Titan prior to production.

### ORANGE COUNTY RESTRICTIONS & REQUIREMENTS

**ALL CREATIVE MUST BE APPROVED BY OCTA PRIOR TO PRODUCTION.**

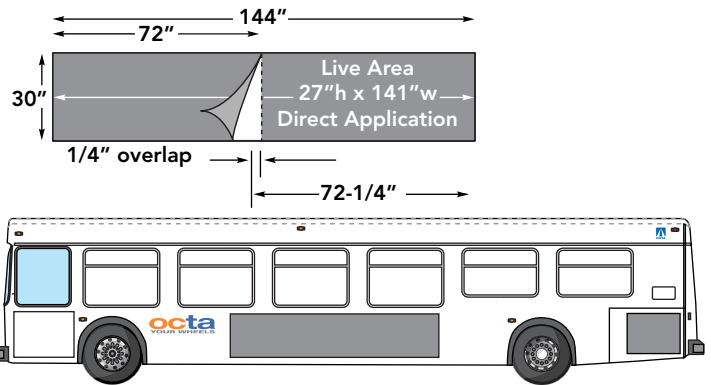

### SHIPPING ADDRESS

**Ship to** Outdoor Service Providers  
10601 Calle Lee, Suite 190  
Los Alamitos, CA 90720

**Phone** 714.229.0600 **Fax** 714.229.0660

**Contact** Oscar  
warehouse@collegebillboardnetwork.com

### DELIVERY

Titan Operations must receive materials 10 days prior to post date. Please include posting instructions and copy of creative with the poster shipment.

## Production Spec Sheet // Kong-Size Bus Poster Display

### UNIT INFORMATION

<b>Finished Size</b>	36"H X 226"W
<b>Live Copy Area</b>	36"H X 226"W
<b>Mechanical Size</b>	9"H X 56-1/2"W

### MECHANICAL(S)

<b>Scale</b>	1/4
<b>DPI @ Finished Size</b>	150 DPI
<b>DPI @ Mechanical Size</b>	600 DPI

### OVERAGE

20% overage is required for each month of posting.

### PRINT FABRICATION / FINISHING DETAILS

Copy to be produced in two (2) sections.  
Copy bleeds to edge on all four sides.

Kong sections are installed from right to left.

Registration marks are needed on top and bottom margins to ensure correct placement of sections. The left section should be 36"H x 113"W. The right section should be 36"H x 113-1/4"W - with the left overlapping the right by 1/4". The left edge of right section of overlap must be unprinted, unvarnished and unlaminated.

For digital processes, an overlamine is required.  
For screen printing and lithography processes, UV or conventional clear coat in compliance with product bulletin specification of substrate/ink manufacturers.

### INKS

Inks must be weatherproof/waterproof with standard UV protection, and must conform to product bulletin specifications of substrate manufacturer.

### MATERIAL / SUBSTRATE(S)

**VINYL:** Removable Transit Vinyl

### REQUIRED VINYL SUBSTRATE(S)

**3M** - IJ36

**GENERAL FORMULATION** - MetroMark

**FLEXCON** - BUSmark 5800  
(5100 will not be accepted)

**SEE TITAN APPROVED SUBSTRATE TABLE FOR COMPLETE LIST OF RECOMMENDED FILMS**

Appropriate overlaminates must be used in conjunction with the materials as listed above and/or appropriate UV clear coat.

**NOTE:** Any substitutions will require written authorization from Titan prior to production.

### ORANGE COUNTY RESTRICTIONS & REQUIREMENTS

**ALL CREATIVE MUST BE APPROVED BY OCTA PRIOR TO PRODUCTION.**

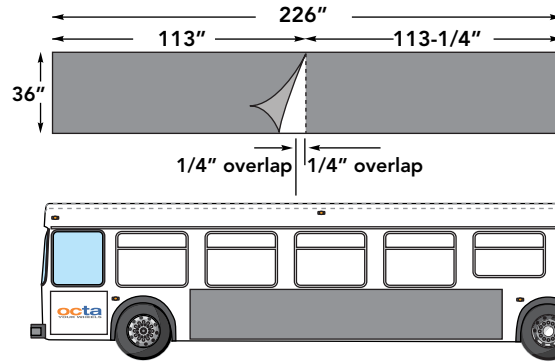

### SHIPPING ADDRESS

**Ship to** Outdoor Service Providers  
10601 Calle Lee, Suite 190  
Los Alamitos, CA 90720

**Phone** 714.229.0600 **Fax** 714.229.0660

**Contact** Oscar  
warehouse@collegebillboardnetwork.com

### DELIVERY

Titan Operations must receive materials 10 days prior to post date. Please include posting instructions and copy of creative with the poster shipment.



## Production Spec Sheet // Headliner Bus Display

### UNIT INFORMATION

<b>Finished Size</b>	14"H X 372"W
<b>Live Copy Area</b>	14"H X 372"W
<b>Mechanical Size</b>	7"H X 186"W

### MECHANICAL(S)

<b>Scale</b>	1/2
<b>DPI @ Finished Size</b>	150 DPI
<b>DPI @ Mechanical Size</b>	300 DPI

### OVERAGE

10% overage is required for each month of posting.

### PRINT FABRICATION / FINISHING DETAILS

Copy to be produced in six (6) sections.  
Copy bleeds to edge on all four sides.

Headliner sections are installed from right to left.

Registration marks are needed on top and bottom margins to ensure correct placement of sections. The far left section should be 14"H x 62"W. The other sections should be 14"H x 62-1/4"W - with the left overlapping the right by 1/4". The left edge of right section of overlap must be unprinted, unvarnished and unlaminated.

For digital processes, an overlamine is required.  
For screen printing and lithography processes, UV or conventional clear coat in compliance with product bulletin specification of substrate/ink manufacturers.

### INKS

Inks must be weatherproof/waterproof with standard UV protection, and must conform to product bulletin specifications of substrate manufacturer.

### MATERIAL / SUBSTRATE(S)

**VINYL:** Removable Transit Vinyl

### REQUIRED VINYL SUBSTRATE(S)

**3M** - IJ36

**GENERAL FORMULATION** - MetroMark

**FLEXCON** - BUSmark 5800  
(5100 will not be accepted)

**SEE TITAN APPROVED SUBSTRATE TABLE FOR COMPLETE LIST OF RECOMMENDED FILMS**

Appropriate overlaminates must be used in conjunction with the materials as listed above and/or appropriate UV clear coat.

**NOTE:** Any substitutions will require written authorization from Titan prior to production.

### ORANGE COUNTY RESTRICTIONS & REQUIREMENTS

**ALL CREATIVE MUST BE APPROVED BY OCTA PRIOR TO PRODUCTION.**

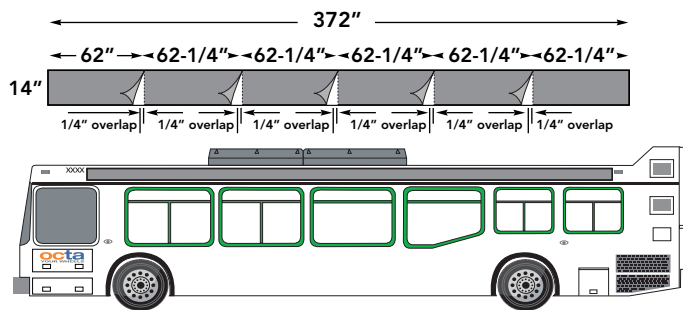

### SHIPPING ADDRESS

**Ship to** Outdoor Service Providers  
10601 Calle Lee, Suite 190  
Los Alamitos, CA 90720

**Phone** 714.229.0600 **Fax** 714.229.0660

**Contact** Oscar  
warehouse@collegebillboardnetwork.com

### DELIVERY

Titan Operations must receive materials 10 days prior to post date. Please include posting instructions and copy of creative with the poster shipment.



## UNIT INFORMATION

**Finished Size** SEE DIAGRAM

## MECHANICAL(S)

**Scale** 1/2  
**DPI @ Finished Size** 150 DPI  
**DPI @ Mechanical Size** 300 DPI

## OVERAGE

20% overage is required for each month of posting.

## PRINT FABRICATION / FINISHING DETAILS

Headliner copy to be produced in two (2) sections.  
 Kong copy to be produced in one (1) section.  
 Copy bleeds to edge on all four sides.

Headliner sections are installed from right to left.  
 Kong sections are installed from right to left.

Headliner: Registration marks are needed on top and bottom margins to ensure correct placement of sections. The far left section should be 9"H x 98"W. The right section should be 9"H x 98-1/4"W - with the left overlapping the right by 1/4". The left edge of right section of overlap must be unprinted, unvarnished and unlaminated.

Kong: Please see diagram.

For digital processes, an overlamine is required.  
 For screen printing and lithography processes, UV or conventional clear coat in compliance with product bulletin specification of substrate/ink manufacturers.

## INKS

Inks must be weatherproof/waterproof with standard UV protection, and must conform to product bulletin specifications of substrate manufacturer.

## MATERIAL / SUBSTRATE(S)

**VINYL:** Removable Transit Vinyl

## REQUIRED VINYL SUBSTRATE(S)

**3M** - IJ3552 w/ 8519 overlamine

Appropriate overlaminates must be used in conjunction with the materials as listed above and/or appropriate UV clear coat.

### NOTE:

- A vector template is available upon request.
- Any substitutions will require written authorization from Titan prior to production.

## ORANGE COUNTY RESTRICTIONS & REQUIREMENTS

**ALL CREATIVE MUST BE APPROVED BY OCTA PRIOR TO PRODUCTION.**

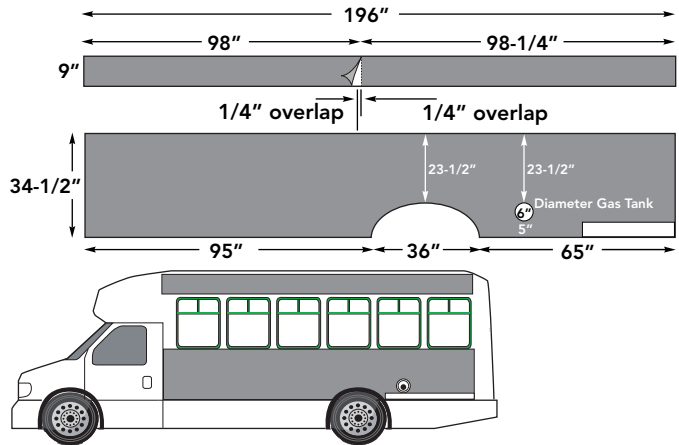

## SHIPPING ADDRESS

**Ship to** Outdoor Service Providers  
 10601 Calle Lee, Suite 190  
 Los Alamitos, CA 90720

**Phone** 714.229.0600 **Fax** 714.229.0660

**Contact** Oscar  
 warehouse@collegebillboardnetwork.com

## DELIVERY

Titan Operations must receive materials 10 days prior to post date. Please include posting instructions and copy of creative with the poster shipment.

## Production Spec Sheet // Interior Car Card Display

### UNIT INFORMATION

<b>Finished Size: (A)</b>	11"H X 28"W
<b>Safety Copy Area</b>	9-7/8"H X 27"W
<b>Mechanical Size</b>	5-1/2"H X 14"W

<b>Finished Size: (B)</b>	11"H X 42"W
<b>Safety Copy Area</b>	9-7/8"H X 41"W
<b>Mechanical Size</b>	5-1/2"H X 21"W

### MECHANICAL(S)

<b>Scale</b>	1/2
<b>DPI @ Finished Size</b>	150 DPI
<b>DPI @ Mechanical Size</b>	300 DPI

### OVERAGE

50% overage is required for each month of posting.

### PRINT FABRICATION

Copy to be produced in one (1) piece.  
Copy bleeds to edge on all four sides.

### INKS

Inks must be weatherproof/waterproof with standard UV protection, and must conform to product bulletin specifications of substrate manufacturer.

### MATERIAL / SUBSTRATE(S)

- 18 pt. Card Stock

**SEE TITAN APPROVED SUBSTRATE TABLE FOR COMPLETE LIST OF RECOMMENDED FILMS**

Appropriate overlaminates must be used in conjunction with the materials as listed above and/or appropriate UV clear coat.

**NOTE:** Any substitutions will require written authorization from Titan prior to production.

### ORANGE COUNTY RESTRICTIONS & REQUIREMENTS

**ALL CREATIVE MUST BE APPROVED BY OCTA PRIOR TO PRODUCTION.**

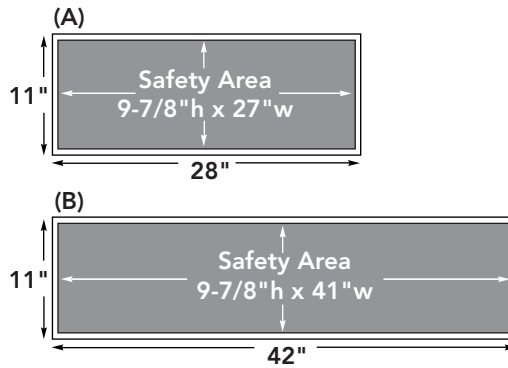

### SHIPPING ADDRESS

<b>Ship to</b>	Outdoor Service Providers 10601 Calle Lee, Suite 190 Los Alamitos, CA 90720		
<b>Phone</b>	714.229.0600	<b>Fax</b>	714.229.0660
<b>Contact</b>	Oscar warehouse@collegebillboardnetwork.com		

### DELIVERY

Titan Operations must receive materials 10 days prior to post date. Please include posting instructions and copy of creative with the poster shipment.

## Production Spec Sheet // Take-One Pad

### UNIT INFORMATION

**Finished Size** 4-1/16" H X 5-1/4" W

### PRINT FABRICATION

Take-Ones are permitted on 24pt. 11"H x 28"W Car Cards ONLY. A maximum of two pads per Car Card - each containing no more than 50 Take-One sheets.

They must be fixed to Car Cards with Adjust-A-Lock fasteners prior to shipping.

### MATERIAL / SUBSTRATE(S)

- 9pt. high bulk business reply stock perforated for easy dispensing

**SEE TITAN APPROVED SUBSTRATE TABLE FOR COMPLETE LIST OF RECOMMENDED FILMS**

Appropriate overlaminates must be used in conjunction with the materials as listed above and/or appropriate UV clear coat.

#### NOTE:

- DO NOT EXCEED OVERALL MEASUREMENT
- Arrow Head fasteners are also accepted.
- Any substitutions will require written authorization from Titan prior to production.
- For use with 11"H x 28"W Interior Car Cards.

### ORANGE COUNTY RESTRICTIONS & REQUIREMENTS

**ALL CREATIVE MUST BE APPROVED BY OCTA PRIOR TO PRODUCTION.**

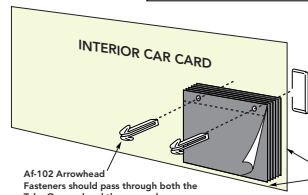
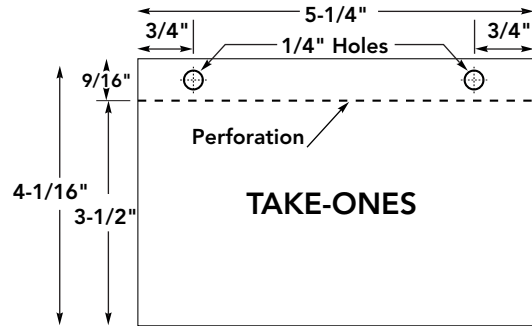

AF-102 Arrowhead Fasteners should pass through both the Take-One pad and the car card copy

#### IMPORTANT NOTE:

Please place the pad at least 1" in from the side and 1" in from the bottom due to frames. Pads should be placed on the corners of the car card.



### SHIPPING ADDRESS

**Ship to** Outdoor Service Providers  
10601 Calle Lee, Suite 190  
Los Alamitos, CA 90720

**Phone** 714.229.0600 **Fax** 714.229.0660

**Contact** Oscar  
warehouse@collegebillboardnetwork.com

### DELIVERY

Titan Operations must receive materials 10 days prior to post date. Please include posting instructions and copy of creative with the poster shipment.

**LOS ANGELES / LADOT**

TAILLIGHT BUS POSTER DISPLAY

SUPER TAILLIGHT BUS POSTER DISPLAYS - GILLIG

TWO-SHEET TAILLIGHT BUS POSTER DISPLAYS - EZ RIDER

TWO-SHEET TAILLIGHT BUS POSTER DISPLAYS - EZ RIDER II

SUPER TAILLIGHT BUS POSTER DISPLAYS - EZ RIDER

SUPER TAILLIGHT BUS POSTER DISPLAYS - EZ RIDER II

QUEEN-SIZE BUS POSTER DISPLAY - DASH

KING-SIZE BUS POSTER DISPLAY - COMMUTER EXPRESS

KONG-SIZE POSTER DISPLAY - GILLIGS

KONG-SIZE POSTER DISPLAY - NEOPLAN

WINDOW CLING DISPLAY - COMMUTER EXPRESS

INTERIOR CAR CARD DISPLAY

TAKE-ONE PAD

## Production Spec Sheet // Taillight Bus Poster Display

### UNIT INFORMATION

<b>Finished Size</b>	21" h x 72" w
<b>Live Copy Area</b>	17" h x 68" w
<b>Mechanical Size</b>	10-1/2" h x 36" w

### MECHANICAL(S)

<b>Scale</b>	1/2
<b>DPI @ Finished Size</b>	150 DPI
<b>DPI @ Mechanical Size</b>	300 DPI

### OVERAGE

20% overage is required for each month of posting.

### PRINT FABRICATION / FINISHING DETAILS

Copy to be produced in one (1) piece.  
Copy bleeds to edge on all four sides.

For digital processes, an overlamine is required.  
For screen printing and lithography processes, UV or conventional clear coat in compliance with product bulletin specification of substrate/ink manufacturers.

### INKS

Inks must be weatherproof/waterproof with standard UV protection, and must conform to product bulletin specifications of substrate manufacturer.

### MATERIAL / SUBSTRATE(S)

**VINYL:** Removable Transit Vinyl

### REQUIRED VINYL SUBSTRATE(S)

**3M** - IJ36

**GENERAL FORMULATION** - MetroMark

**FLEXCON** - BUSmark 5800  
(5100 will not be accepted)

[SEE TITAN APPROVED SUBSTRATE TABLE FOR COMPLETE LIST OF RECOMMENDED FILMS](#)

Appropriate overlaminates must be used in conjunction with the materials as listed above and/or appropriate UV clear coat.

**NOTE:** Any substitutions will require written authorization from Titan prior to production.

### LADOT RESTRICTIONS & REQUIREMENTS

[ALL CREATIVE MUST BE APPROVED BY LADOT PRIOR TO PRODUCTION.](#)

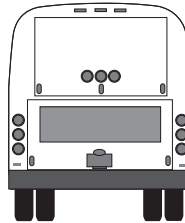
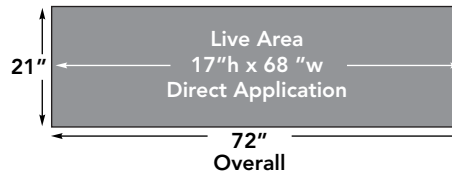

### SHIPPING ADDRESS

**Ship to** Outdoor Service Providers  
10601 Calle Lee, Suite 190  
Los Alamitos, CA 90720

**Phone** 714.229.0600 **Fax** 714.229.0660

**Contact** Oscar  
warehouse@collegebillboardnetwork.com

### DELIVERY

Titan Operations must receive materials 10 days prior to post date.  
Please include posting instructions and copy of creative with the poster shipment.

## Production Spec Sheet // Super Taillight Bus Poster Display - GILLIG

### UNIT INFORMATION

<b>Finished Size</b>	36-1/2" H X 69-1/2" W
<b>Live Copy Area</b>	See Diagram
<b>Mechanical Size</b>	18-1/4" H X 34-3/4" W

### MECHANICAL(S)

<b>Scale</b>	1/2
<b>DPI @ Finished Size</b>	150 DPI
<b>DPI @ Mechanical Size</b>	300 DPI

### OVERAGE

20% overage is required for each month of posting.

### PRINT FABRICATION / FINISHING DETAILS

Copy to be produced in one (1) piece.  
Copy bleeds to edge on all four sides.

For digital processes, an overlamine is required.  
For screen printing and lithography processes, UV or conventional clear coat in compliance with product bulletin specification of substrate/ink manufacturers.

### INKS

Inks must be weatherproof/waterproof with standard UV protection, and must conform to product bulletin specifications of substrate manufacturer.

### MATERIAL / SUBSTRATE(S)

**VINYL:** Removable Transit Vinyl

### REQUIRED VINYL SUBSTRATE(S)

3M - IJ36

**GENERAL FORMULATION** - MetroMark

**FLEXCON** - BUSmark 5800  
(5100 will not be accepted)

**SEE TITAN APPROVED SUBSTRATE TABLE FOR COMPLETE LIST OF RECOMMENDED FILMS**

Appropriate overlaminates must be used in conjunction with the materials as listed above and/or appropriate UV clear coat.

#### NOTE:

- Any substitutions will require written authorization from Titan prior to production.
- Taillight Display should be designed to avoid the license plate and door handle. A vector scaled template will be provided upon request.

### LADOT RESTRICTIONS & REQUIREMENTS

**ALL CREATIVE MUST BE APPROVED BY LADOT PRIOR TO PRODUCTION.**

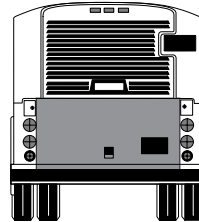
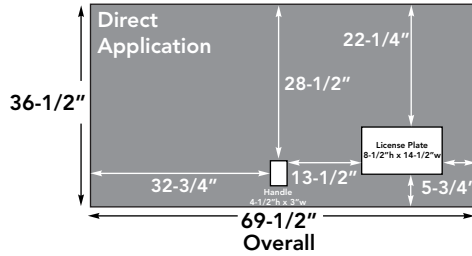

### SHIPPING ADDRESS

**Ship to** Outdoor Service Providers  
10601 Calle Lee, Suite 190  
Los Alamitos, CA 90720

**Phone** 714.229.0600 **Fax** 714.229.0660

**Contact** Oscar  
warehouse@collegebillboardnetwork.com

### DELIVERY

Titan Operations must receive materials 10 days prior to post date. Please include posting instructions and copy of creative with the poster shipment.



## Production Spec Sheet // Two-Sheet Taillight Bus Poster Display - EZ RIDER

### UNIT INFORMATION

<b>Finished Size</b>	46"H X 60"W
<b>Live Copy Area</b>	See Diagram
<b>Mechanical Size</b>	23"H X 30"W

### MECHANICAL(S)

<b>Scale</b>	1/2
<b>DPI @ Finished Size</b>	150 DPI
<b>DPI @ Mechanical Size</b>	300 DPI

### OVERAGE

20% overage is required for each month of posting.

### PRINT FABRICATION / FINISHING DETAILS

Copy to be produced in one (1) piece.  
Copy bleeds to edge on all four sides.

For digital processes, an overlamine is required.  
For screen printing and lithography processes, UV or conventional clear coat in compliance with product bulletin specification of substrate/ink manufacturers.

### INKS

Inks must be weatherproof/waterproof with standard UV protection, and must conform to product bulletin specifications of substrate manufacturer.

### MATERIAL / SUBSTRATE(S)

**VINYL:** Removable Transit Vinyl

### REQUIRED VINYL SUBSTRATE(S)

3M - IJ36

**GENERAL FORMULATION** - MetroMark

**FLEXCON** - BUSmark 5800  
(5100 will not be accepted)

[SEE TITAN APPROVED SUBSTRATE TABLE FOR COMPLETE LIST OF RECOMMENDED FILMS](#)

Appropriate overlaminates must be used in conjunction with the materials as listed above and/or appropriate UV clear coat.

**NOTE:**

- Any substitutions will require written authorization from Titan prior to production.
- Taillight Display should be designed to avoid the license plate. A vector scaled template will be provided upon request.

### LADOT RESTRICTIONS & REQUIREMENTS

**ALL CREATIVE MUST BE APPROVED BY LADOT PRIOR TO PRODUCTION.**

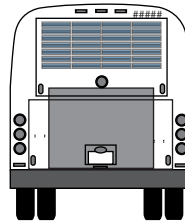
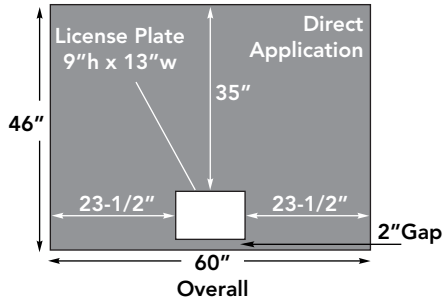

### SHIPPING ADDRESS

**Ship to** Outdoor Service Providers  
10601 Calle Lee, Suite 190  
Los Alamitos, CA 90720

**Phone** 714.229.0600 **Fax** 714.229.0660

**Contact** Oscar  
warehouse@collegebillboardnetwork.com

### DELIVERY

Titan Operations must receive materials 10 days prior to post date. Please include posting instructions and copy of creative with the poster shipment.



## Production Spec Sheet // Two-Sheet Taillight Bus Poster Display - EZ RIDER II

### UNIT INFORMATION

<b>Finished Size</b>	46" H X 60" W
<b>Live Copy Area</b>	42" H X 56" W
<b>Mechanical Size</b>	23" H X 30" W

### MECHANICAL(S)

<b>Scale</b>	1/2
<b>DPI @ Finished Size</b>	150 DPI
<b>DPI @ Mechanical Size</b>	300 DPI

### OVERAGE

20% overage is required for each month of posting.

### PRINT FABRICATION / FINISHING DETAILS

Copy to be produced in one (1) piece.  
Copy bleeds to edge on all four sides.

For digital processes, an overlamine is required.  
For screen printing and lithography processes, UV or conventional clear coat in compliance with product bulletin specification of substrate/ink manufacturers.

### INKS

Inks must be weatherproof/waterproof with standard UV protection, and must conform to product bulletin specifications of substrate manufacturer.

### MATERIAL / SUBSTRATE(S)

**VINYL:** Removable Transit Vinyl

### REQUIRED VINYL SUBSTRATE(S)

**3M** - IJ36

**GENERAL FORMULATION** - MetroMark

**FLEXCON** - BUSmark 5800  
(5100 will not be accepted)

[SEE TITAN APPROVED SUBSTRATE TABLE FOR COMPLETE LIST OF RECOMMENDED FILMS](#)

Appropriate overlaminates must be used in conjunction with the materials as listed above and/or appropriate UV clear coat.

**NOTE:** Any substitutions will require written authorization from Titan prior to production.

### LADOT RESTRICTIONS & REQUIREMENTS

[ALL CREATIVE MUST BE APPROVED BY LADOT PRIOR TO PRODUCTION.](#)

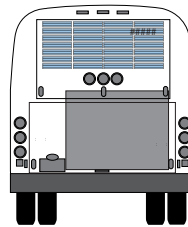
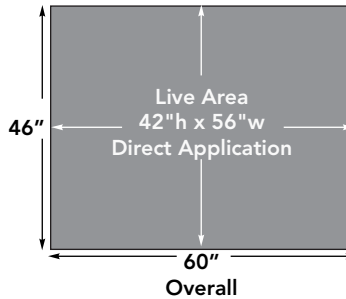

### SHIPPING ADDRESS

**Ship to** Outdoor Service Providers  
10601 Calle Lee, Suite 190  
Los Alamitos, CA 90720

**Phone** 714.229.0600 **Fax** 714.229.0660

**Contact** Oscar  
warehouse@collegebillboardnetwork.com

### DELIVERY

Titan Operations must receive materials 10 days prior to post date. Please include posting instructions and copy of creative with the poster shipment.

## Production Spec Sheet // Super Two-Sheet Taillight Bus Poster Display - EZ RIDER

### UNIT INFORMATION

<b>Finished Size</b>	36"H X 79-1/2"W
<b>Live Copy Area</b>	See Diagram
<b>Mechanical Size</b>	18"H X 39-3/4"W

### MECHANICAL(S)

<b>Scale</b>	1/2
<b>DPI @ Finished Size</b>	150 DPI
<b>DPI @ Mechanical Size</b>	300 DPI

### OVERAGE

20% overage is required for each month of posting.

### PRINT FABRICATION / FINISHING DETAILS

Copy to be produced in one (1) piece.  
Copy bleeds to edge on all four sides.

For digital processes, an overlamine is required.  
For screen printing and lithography processes, UV or conventional clear coat in compliance with product bulletin specification of substrate/ink manufacturers.

### INKS

Inks must be weatherproof/waterproof with standard UV protection, and must conform to product bulletin specifications of substrate manufacturer.

### MATERIAL / SUBSTRATE(S)

**VINYL:** Removable Transit Vinyl

### REQUIRED VINYL SUBSTRATE(S)

3M - IJ36

**GENERAL FORMULATION** - MetroMark

**FLEXCON** - BUSmark 5800  
(5100 will not be accepted)

**SEE TITAN APPROVED SUBSTRATE TABLE FOR COMPLETE LIST OF RECOMMENDED FILMS**

Appropriate overlaminates must be used in conjunction with the materials as listed above and/or appropriate UV clear coat.

#### NOTE:

- Any substitutions will require written authorization from Titan prior to production.
- Taillight Display should be designed to avoid the license plate and door handle. A vector scaled template will be provided upon request.

### LADOT RESTRICTIONS & REQUIREMENTS

**ALL CREATIVE MUST BE APPROVED BY LADOT PRIOR TO PRODUCTION.**

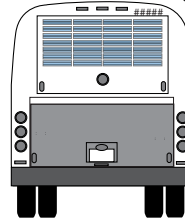
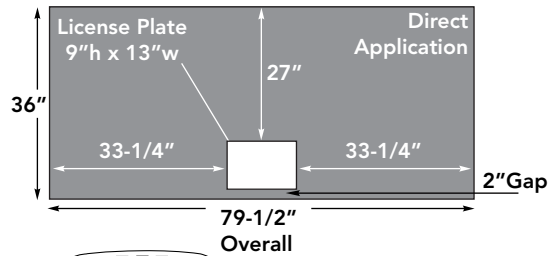

### SHIPPING ADDRESS

**Ship to** Outdoor Service Providers  
10601 Calle Lee, Suite 190  
Los Alamitos, CA 90720

**Phone** 714.229.0600 **Fax** 714.229.0660

**Contact** Oscar  
warehouse@collegebillboardnetwork.com

### DELIVERY

Titan Operations must receive materials 10 days prior to post date. Please include posting instructions and copy of creative with the poster shipment.

## Production Spec Sheet // Super Two-Sheet Taillight Bus Poster Display - EZ RIDER II

### UNIT INFORMATION

<b>Finished Size</b>	36"H X 79-1/2"W
<b>Live Copy Area</b>	See Diagram
<b>Mechanical Size</b>	18"H X 39-3/4"W

### MECHANICAL(S)

<b>Scale</b>	1/2
<b>DPI @ Finished Size</b>	150 DPI
<b>DPI @ Mechanical Size</b>	300 DPI

### OVERAGE

20% overage is required for each month of posting.

### PRINT FABRICATION / FINISHING DETAILS

Copy to be produced in one (1) piece.  
Copy bleeds to edge on all four sides.

For digital processes, an overlamine is required.  
For screen printing and lithography processes, UV or conventional clear coat in compliance with product bulletin specification of substrate/ink manufacturers.

### INKS

Inks must be weatherproof/waterproof with standard UV protection, and must conform to product bulletin specifications of substrate manufacturer.

### MATERIAL / SUBSTRATE(S)

**VINYL:** Removable Transit Vinyl

### REQUIRED VINYL SUBSTRATE(S)

3M - IJ36

**GENERAL FORMULATION** - MetroMark

**FLEXCON** - BUSmark 5800  
(5100 will not be accepted)

**SEE TITAN APPROVED SUBSTRATE TABLE FOR COMPLETE LIST OF RECOMMENDED FILMS**

Appropriate overlaminates must be used in conjunction with the materials as listed above and/or appropriate UV clear coat.

#### NOTE:

- Any substitutions will require written authorization from Titan prior to production.
- Taillight Display should be designed to avoid the license plate and door handle. A vector scaled template will be provided upon request.

### LADOT RESTRICTIONS & REQUIREMENTS

**ALL CREATIVE MUST BE APPROVED BY LADOT PRIOR TO PRODUCTION.**

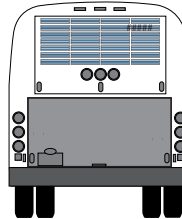
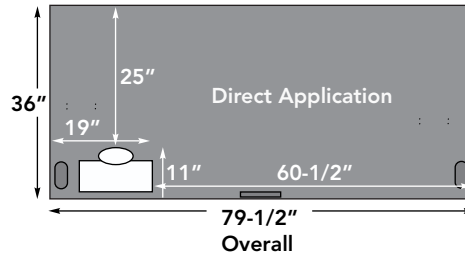

### SHIPPING ADDRESS

**Ship to** Outdoor Service Providers  
10601 Calle Lee, Suite 190  
Los Alamitos, CA 90720

**Phone** 714.229.0600 **Fax** 714.229.0660

**Contact** Oscar  
warehouse@collegebillboardnetwork.com

### DELIVERY

Titan Operations must receive materials 10 days prior to post date. Please include posting instructions and copy of creative with the poster shipment.

## Production Spec Sheet // Queen-Size Bus Poster Display

### UNIT INFORMATION

<b>Finished Size</b>	30"H x 88"W
<b>Live Copy Area</b>	27"H x 85"W
<b>Mechanical Size</b>	15"H x 44"W

### MECHANICAL(S)

<b>Scale</b>	1/2
<b>DPI @ Finished Size</b>	300 DPI
<b>DPI @ Mechanical Size</b>	600 DPI

### OVERAGE

20% overage is required for each month of posting.

### PRINT FABRICATION / FINISHING DETAILS

Copy to be produced in one (1) piece.  
Copy bleeds to edge on all four sides.

For digital processes, an overlamine is required.  
For screen printing and lithography processes, UV or conventional clear coat in compliance with product bulletin specification of substrate/ink manufacturers.

### INKS

Inks must be weatherproof/waterproof with standard UV protection, and must conform to product bulletin specifications of substrate manufacturer.

### MATERIAL / SUBSTRATE

Adhesive Transit Vinyl

### REQUIRED VINYL SUBSTRATE(S)

3M - IJ36

**GENERAL FORMULATION** - MetroMark

**FLEXCON** - BUSmark 5800  
(5100 will not be accepted)

**SEE TITAN APPROVED SUBSTRATE TABLE FOR COMPLETE LIST OF RECOMMENDED FILMS**

Appropriate overlaminates must be used in conjunction with the materials as listed above and/or appropriate UV clear coat.

**NOTE:** Any substitutions will require written authorization from Titan prior to production.

### LADOT RESTRICTIONS & REQUIREMENTS

**ALL CREATIVE MUST BE APPROVED BY LADOT PRIOR TO PRODUCTION.**

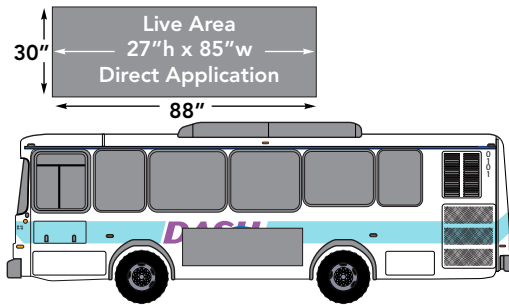

### SHIPPING ADDRESS

**Ship to** Outdoor Service Providers  
10601 Calle Lee, Suite 190  
Los Alamitos, CA 90720

**Phone** 714.229.0600 **Fax** 714.229.0660

**Contact** Oscar  
warehouse@collegebillboardnetwork.com

### DELIVERY

Titan Operations must receive materials 10 days prior to post date. Please include posting instructions and copy of creative with the poster shipment.

## Production Spec Sheet // King-Size Bus Poster Display

### UNIT INFORMATION

<b>Finished Size</b>	30"H X 144"W
<b>Live Copy Area</b>	27"H X 141"W
<b>Mechanical Size</b>	7-1/2"H X 36"W

### MECHANICAL(S)

<b>Scale</b>	1/4
<b>DPI @ Finished Size</b>	150 DPI
<b>DPI @ Mechanical Size</b>	600 DPI

### OVERAGE

20% overage is required for each month of posting.

### PRINT FABRICATION / FINISHING DETAILS

Copy to be produced in two (2) sections.  
Copy bleeds to edge on all four sides.

King sections are installed from right to left.

Registration marks are needed on top and bottom margins to ensure correct placement of sections. The left section should be 30"H x 72"W. The right section should be 30"H x 72-1/4"W - with the left overlapping the right by 1/4". The left edge of right section of overlap must be unprinted, unvarnished and unlaminated.

For digital processes, an overlamine is required.  
For screen printing and lithography processes, UV or conventional clear coat in compliance with product bulletin specification of substrate/ink manufacturers.

### INKS

Inks must be weatherproof/waterproof with standard UV protection, and must conform to product bulletin specifications of substrate manufacturer.

### MATERIAL / SUBSTRATE(S)

**VINYL:** Removable Transit Vinyl

### REQUIRED VINYL SUBSTRATE(S)

**3M** - IJ36

**GENERAL FORMULATION** - MetroMark

**FLEXCON** - BUSmark 5800  
(5100 will not be accepted)

**SEE TITAN APPROVED SUBSTRATE TABLE FOR COMPLETE LIST OF RECOMMENDED FILMS**

Appropriate overlaminates must be used in conjunction with the materials as listed above and/or appropriate UV clear coat.

**NOTE:** Any substitutions will require written authorization from Titan prior to production.

### LADOT RESTRICTIONS & REQUIREMENTS

**ALL CREATIVE MUST BE APPROVED BY LADOT PRIOR TO PRODUCTION.**

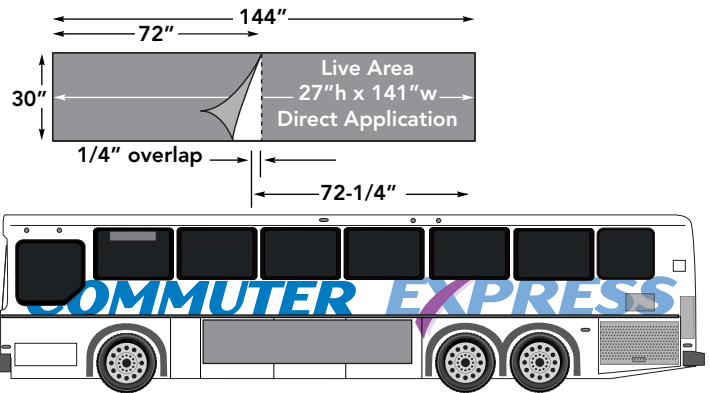

### SHIPPING ADDRESS

**Ship to** Outdoor Service Providers  
10601 Calle Lee, Suite 190  
Los Alamitos, CA 90720

**Phone** 714.229.0600 **Fax** 714.229.0660

**Contact** Oscar  
warehouse@collegebillboardnetwork.com

### DELIVERY

Titan Operations must receive materials 10 days prior to post date. Please include posting instructions and copy of creative with the poster shipment.



Production Spec Sheet // Kong-Size Bus Poster Display

UNIT INFORMATION

Finished Size	49"H X 225"W
Live Copy Area	49"H X 225"W
Mechanical Size	12-1/4"H X 56-1/4"W

MECHANICAL(S)

Scale	1/4
DPI @ Finished Size	150 DPI
DPI @ Mechanical Size	600 DPI

OVERAGE

5% overage is required for each month of posting.

PRINT FABRICATION / FINISHING DETAILS

Copy to be produced in two (2) sections.  
Copy bleeds to edge on all four sides.

Kong sections are installed from right to left.

Registration marks are needed on top and bottom margins to ensure correct placement of sections. The left section should be 49"H x 112-1/2"W. The right section should be 49"H x 112-3/4"W - with the left overlapping the right by 1/4". The left edge of right section of overlap must be unprinted, unvarnished and unlaminated.

For digital processes, an overlamine is required.  
For screen printing and lithography processes, UV or conventional clear coat in compliance with product bulletin specification of substrate/ink manufacturers.

INKS

Inks must be weatherproof/waterproof with standard UV protection, and must conform to product bulletin specifications of substrate manufacturer.

MATERIAL / SUBSTRATE(S)

**VINYL:** Removable Transit Vinyl

REQUIRED VINYL SUBSTRATE(S)

**3M** - IJ36

**GENERAL FORMULATION** - MetroMark

**FLEXCON** - BUSmark 5800  
(5100 will not be accepted)

**SEE TITAN APPROVED SUBSTRATE TABLE FOR COMPLETE LIST OF RECOMMENDED FILMS**

Appropriate overlaminates must be used in conjunction with the materials as listed above and/or appropriate UV clear coat.

**NOTE:** Any substitutions will require written authorization from Titan prior to production.

LADOT RESTRICTIONS & REQUIREMENTS

**ALL CREATIVE MUST BE APPROVED BY LADOT PRIOR TO PRODUCTION.**

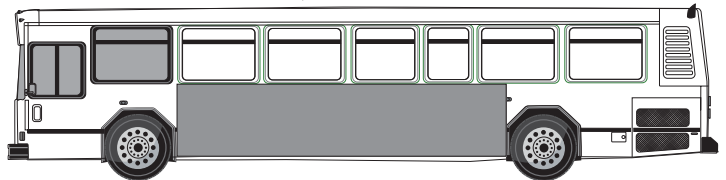
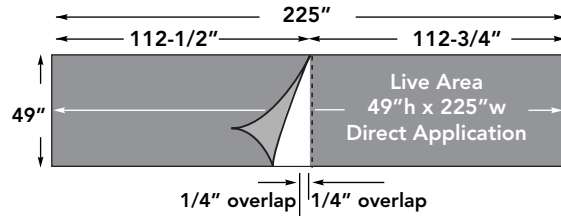

SHIPPING ADDRESS

**Ship to** Outdoor Service Providers  
10601 Calle Lee, Suite 190  
Los Alamitos, CA 90720

**Phone** 714.229.0600 **Fax** 714.229.0660

**Contact** Oscar  
warehouse@collegebillboardnetwork.com

DELIVERY

Titan Operations must receive materials 10 days prior to post date. Please include posting instructions and copy of creative with the poster shipment.

## Production Spec Sheet // Kong-Size Bus Poster Display

### UNIT INFORMATION

<b>Finished Size</b>	66"H X 178"W
<b>Live Copy Area</b>	66"H X 178"W
<b>Mechanical Size</b>	16-1/2"H X 44-1/2"W

### MECHANICAL(S)

<b>Scale</b>	1/4
<b>DPI @ Finished Size</b>	150 DPI
<b>DPI @ Mechanical Size</b>	600 DPI

### OVERAGE

5% overage is required for each month of posting.

### PRINT FABRICATION / FINISHING DETAILS

Copy to be produced in two (2) sections.  
Copy bleeds to edge on all four sides.

King sections are installed from right to left.

Registration marks are needed on top and bottom margins to ensure correct placement of sections. The left section should be 66"H x 89"W. The right section should be 66"H x 89-1/4"W - with the left overlapping the right by 1/4". The left edge of right section of overlap must be unprinted, unvarnished and unlaminated.

For digital processes, an overlamine is required.  
For screen printing and lithography processes, UV or conventional clear coat in compliance with product bulletin specification of substrate/ink manufacturers.

### INKS

Inks must be weatherproof/waterproof with standard UV protection, and must conform to product bulletin specifications of substrate manufacturer.

### MATERIAL / SUBSTRATE(S)

**VINYL:** Removable Transit Vinyl

### REQUIRED VINYL SUBSTRATE(S)

**3M** - IJ36

**GENERAL FORMULATION** - MetroMark

**FLEXCON** - BUSmark 5800  
(5100 will not be accepted)

**SEE TITAN APPROVED SUBSTRATE TABLE FOR COMPLETE LIST OF RECOMMENDED FILMS**

Appropriate overlaminates must be used in conjunction with the materials as listed above and/or appropriate UV clear coat.

**NOTE:** Any substitutions will require written authorization from Titan prior to production.

### LADOT RESTRICTIONS & REQUIREMENTS

**ALL CREATIVE MUST BE APPROVED BY LADOT PRIOR TO PRODUCTION.**

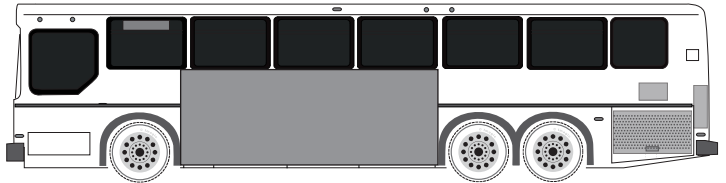
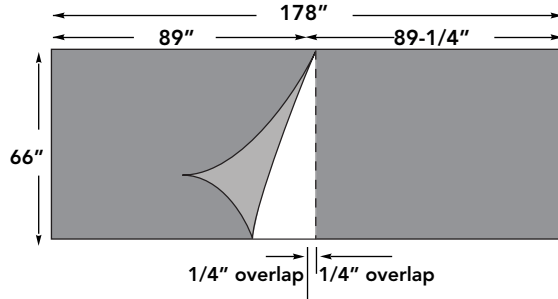

### SHIPPING ADDRESS

**Ship to** Outdoor Service Providers  
10601 Calle Lee, Suite 190  
Los Alamitos, CA 90720

**Phone** 714.229.0600 **Fax** 714.229.0660

**Contact** Oscar  
warehouse@collegebillboardnetwork.com

### DELIVERY

Titan Operations must receive materials 10 days prior to post date. Please include posting instructions and copy of creative with the poster shipment.



## Production Spec Sheet // Window Cling Display

### UNIT INFORMATION

<b>Finished Size: (A) - Street Side</b>	40"H X 326"W
<b>Live Copy Area</b>	40"H X 326"W
<b>Mechanical Size</b>	10"H X 81-1/2"W

<b>Finished Size: (B) - Curb Side</b>	See Diagram
<b>Live Copy Area</b>	
<b>Mechanical Size</b>	

### MECHANICAL(S)

<b>Scale</b>	1/4
<b>DPI @ Finished Size</b>	150 DPI
<b>DPI @ Mechanical Size</b>	600 DPI

### OVERAGE

20% overage is required for each month of posting.

### PRINT FABRICATION / FINISHING DETAILS

(A) - Street Side - Copy for to be produced in one (1) piece.  
 (B) - Curb Side - Copy to be produced in three (3) sections.  
 Copy bleeds to edge on all four sides.

For digital processes, an overlamine is required.  
 For screen printing and lithography processes, UV or conventional clear coat in compliance with product bulletin specification of substrate/ink manufacturers.

### INKS

Inks must be weatherproof/waterproof with standard UV protection, and must conform to product bulletin specifications of substrate manufacturer.

### MATERIAL / SUBSTRATE(S)

**VINYL:** 3M - IJ66 w/ overlamine 3M 8914

**NOTE:** Any substitutions will require written authorization from Titan prior to production.

### LADOT RESTRICTIONS & REQUIREMENTS

**ALL CREATIVE MUST BE APPROVED BY LADOT PRIOR TO PRODUCTION.**

### (A) - Street Side

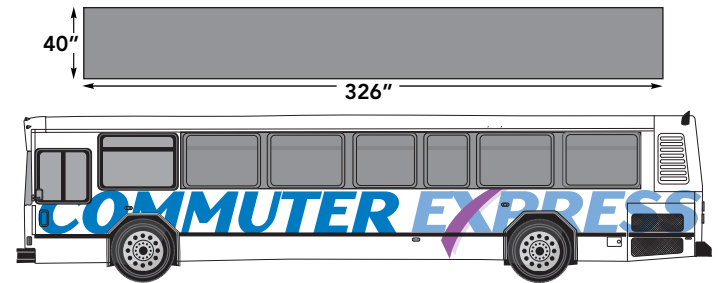

#### IMPORTANT NOTE:

- 1) One piece of window material to go the full length of the ad.
- 2) Black strips are to be provided to go in between the windows.
- 3) Live copy is not to go beyond the window molding. If the printer trims below the windows, then it must be bleed copy only, not live window graphics.

### (B) - Curb Side

- 1) Section (A) - 40"h x 123-1/2"w
- 2) Section (B) - 40"h x 34"w
- 3) Section (C) - 40"h x 168-1/2"w

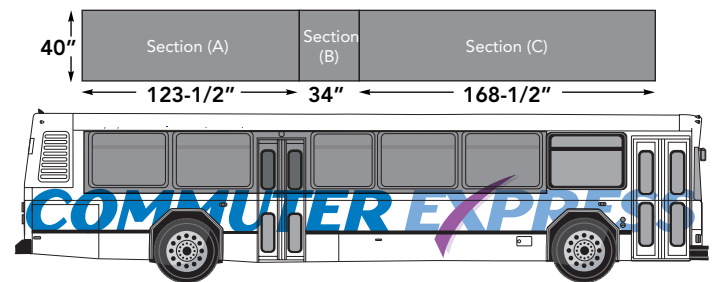

#### IMPORTANT NOTE:

- Curb Side:
- 1) The Curb Side must be printed in three (3) pieces.
  - 2) Black strips are to be provided to go in between the windows and on the door.
  - 3) Live copy is not to go beyond the window molding. If the printer trims below the windows, then it must be bleed copy only, not live window graphics.

### SHIPPING ADDRESS

**Ship to** Outdoor Service Providers  
 10601 Calle Lee, Suite 190  
 Los Alamitos, CA 90720

**Phone** 714.229.0600 **Fax** 714.229.0660

**Contact** Oscar  
 warehouse@collegebillboardnetwork.com

### DELIVERY

Titan Operations must receive materials 10 days prior to post date. Please include posting instructions and copy of creative with the poster shipment.

## Production Spec Sheet // Interior Car Card Display

### UNIT INFORMATION

<b>Finished Size: (A)</b>	11"H X 28"W
<b>Safety Copy Area</b>	9-7/8"H X 27"W
<b>Mechanical Size</b>	5-1/2"H X 14"W
<b>Finished Size: (B)</b>	11"H X 42"W
<b>Safety Copy Area</b>	9-7/8"H X 41"W
<b>Mechanical Size</b>	5-1/2"H X 21"W

### MECHANICAL(S)

<b>Scale</b>	1/2
<b>DPI @ Finished Size</b>	150 DPI
<b>DPI @ Mechanical Size</b>	300 DPI

### OVERAGE

50% overage is required for each month of posting.

### PRINT FABRICATION

Copy to be produced in one (1) piece.  
Copy bleeds to edge on all four sides.

### INKS

Inks must be weatherproof/waterproof with standard UV protection, and must conform to product bulletin specifications of substrate manufacturer.

### MATERIAL / SUBSTRATE(S)

- 18 pt. Card Stock

**SEE TITAN APPROVED SUBSTRATE TABLE FOR COMPLETE LIST OF RECOMMENDED FILMS**

Appropriate overlaminates must be used in conjunction with the materials as listed above and/or appropriate UV clear coat.

**NOTE:** Any substitutions will require written authorization from Titan prior to production.

### LADOT RESTRICTIONS & REQUIREMENTS

**ALL CREATIVE MUST BE APPROVED BY LADOT PRIOR TO PRODUCTION.**

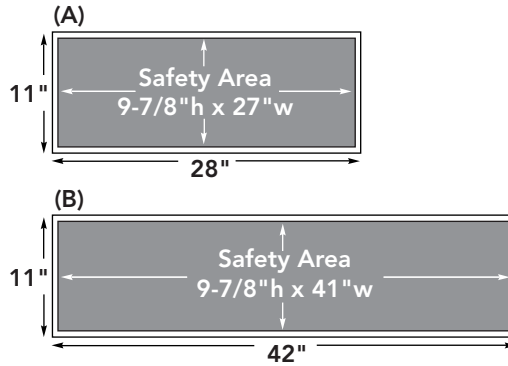

### SHIPPING ADDRESS

**Ship to** Outdoor Service Providers  
10601 Calle Lee, Suite 190  
Los Alamitos, CA 90720

**Phone** 714.229.0600 **Fax** 714.229.0660

**Contact** Oscar  
warehouse@collegebillboardnetwork.com

### DELIVERY

Titan Operations must receive materials 10 days prior to post date. Please include posting instructions and copy of creative with the poster shipment.

## UNIT INFORMATION

**Finished Size** 4-1/16" H X 5-1/4" W

## PRINT FABRICATION

Take-Ones are permitted on 24pt. 11"H x 28"W Car Cards ONLY. A maximum of two pads per Car Card - each containing no more than 50 Take-One sheets.

They must be fixed to Car Cards with Adjust-A-Lock fasteners prior to shipping.

## MATERIAL / SUBSTRATE(S)

- 9pt. high bulk business reply stock perforated for easy dispensing

**SEE TITAN APPROVED SUBSTRATE TABLE FOR COMPLETE LIST OF RECOMMENDED FILMS**

Appropriate overlaminates must be used in conjunction with the materials as listed above and/or appropriate UV clear coat.

### NOTE:

- DO NOT EXCEED OVERALL MEASUREMENT
- Arrow Head fasteners are also accepted.
- Any substitutions will require written authorization from Titan prior to production.
- For use with 11"H x 28"W Interior Car Cards.

## ORANGE COUNTY RESTRICTIONS & REQUIREMENTS

**ALL CREATIVE MUST BE APPROVED BY OCTA PRIOR TO PRODUCTION.**

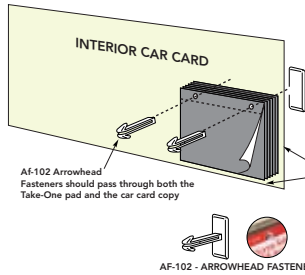
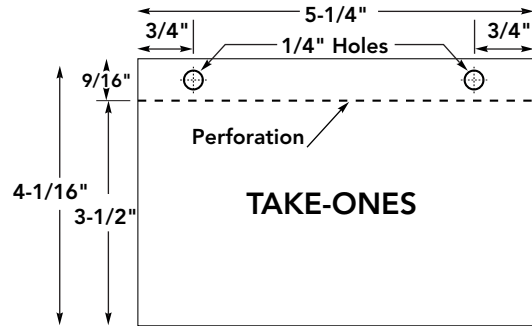

**IMPORTANT NOTE:**  
Please place the pad at least 1" from the side and 1" from the bottom due to frames. Pads should be placed on the corners of the car card.



## SHIPPING ADDRESS

**Ship to** Outdoor Service Providers  
10601 Calle Lee, Suite 190  
Los Alamitos, CA 90720

**Phone** 714.229.0600 **Fax** 714.229.0660

**Contact** Oscar  
warehouse@collegebillboardnetwork.com

## DELIVERY

Titan Operations must receive materials 10 days prior to post date. Please include posting instructions and copy of creative with the poster shipment.

LOS ANGELES - LADOT

**LONG BEACH / LBT**

TAILLIGHT BUS POSTER DISPLAY

KING-SIZE BUS POSTER DISPLAY

## Production Spec Sheet // Taillight Bus Poster Display

### UNIT INFORMATION

<b>Finished Size</b>	21" h x 72" w
<b>Live Copy Area</b>	17" h x 68" w
<b>Mechanical Size</b>	10-1/2" h x 36" w

### MECHANICAL(S)

<b>Scale</b>	1/2
<b>DPI @ Finished Size</b>	150 DPI
<b>DPI @ Mechanical Size</b>	300 DPI

### OVERAGE

20% overage is required for each month of posting.

### PRINT FABRICATION / FINISHING DETAILS

Copy to be produced in one (1) piece.  
Copy bleeds to edge on all four sides.

For digital processes, an overlamine is required.  
For screen printing and lithography processes, UV or conventional clear coat in compliance with product bulletin specification of substrate/ink manufacturers.

### INKS

Inks must be weatherproof/waterproof with standard UV protection, and must conform to product bulletin specifications of substrate manufacturer.

### MATERIAL / SUBSTRATE(S)

**VINYL:** Removable Transit Vinyl

### REQUIRED VINYL SUBSTRATE(S)

**3M** - IJ36

**GENERAL FORMULATION** - MetroMark

**FLEXCON** - BUSmark 5800  
(5100 will not be accepted)

[SEE TITAN APPROVED SUBSTRATE TABLE FOR COMPLETE LIST OF RECOMMENDED FILMS](#)

Appropriate overlaminates must be used in conjunction with the materials as listed above and/or appropriate UV clear coat.

**NOTE:** Any substitutions will require written authorization from Titan prior to production.

### LONG BEACH RESTRICTIONS & REQUIREMENTS

[ALL CREATIVE MUST BE APPROVED BY LBT PRIOR TO PRODUCTION.](#)

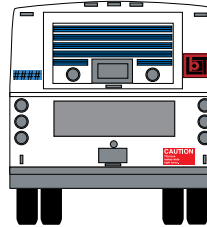
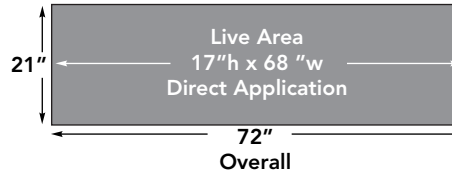

### SHIPPING ADDRESS

**Ship to** Outdoor Service Providers  
10601 Calle Lee, Suite 190  
Los Alamitos, CA 90720

**Phone** 714.229.0600 **Fax** 714.229.0660

**Contact** Oscar  
warehouse@collegebillboardnetwork.com

### DELIVERY

Titan Operations must receive materials 10 days prior to post date. Please include posting instructions and copy of creative with the poster shipment.

## Production Spec Sheet // King-Size Bus Poster Display

### UNIT INFORMATION

<b>Finished Size</b>	30"H X 144"W
<b>Live Copy Area</b>	27"H X 141"W
<b>Mechanical Size</b>	7-1/2"H X 36"W

### MECHANICAL(S)

<b>Scale</b>	1/4
<b>DPI @ Finished Size</b>	150 DPI
<b>DPI @ Mechanical Size</b>	600 DPI

### OVERAGE

20% overage is required for each month of posting.

### PRINT FABRICATION / FINISHING DETAILS

Copy to be produced in two (2) sections.  
Copy bleeds to edge on all four sides.

King sections are installed from right to left.

Registration marks are needed on top and bottom margins to ensure correct placement of sections. The left section should be 30"H x 72"W. The right section should be 30"H x 72-1/4"W - with the left overlapping the right by 1/4". The left edge of right section of overlap must be unprinted, unvarnished and unlaminated.

For digital processes, an overlamine is required.  
For screen printing and lithography processes, UV or conventional clear coat in compliance with product bulletin specification of substrate/ink manufacturers.

### INKS

Inks must be weatherproof/waterproof with standard UV protection, and must conform to product bulletin specifications of substrate manufacturer.

### MATERIAL / SUBSTRATE(S)

**VINYL:** Removable Transit Vinyl

### REQUIRED VINYL SUBSTRATE(S)

**3M** - IJ36

**GENERAL FORMULATION** - MetroMark

**FLEXCON** - BUSmark 5800  
(5100 will not be accepted)

**SEE TITAN APPROVED SUBSTRATE TABLE FOR COMPLETE LIST OF RECOMMENDED FILMS**

Appropriate overlaminates must be used in conjunction with the materials as listed above and/or appropriate UV clear coat.

**NOTE:** Any substitutions will require written authorization from Titan prior to production.

### LONG BEACH RESTRICTIONS & REQUIREMENTS

**ALL CREATIVE MUST BE APPROVED BY LBT PRIOR TO PRODUCTION.**

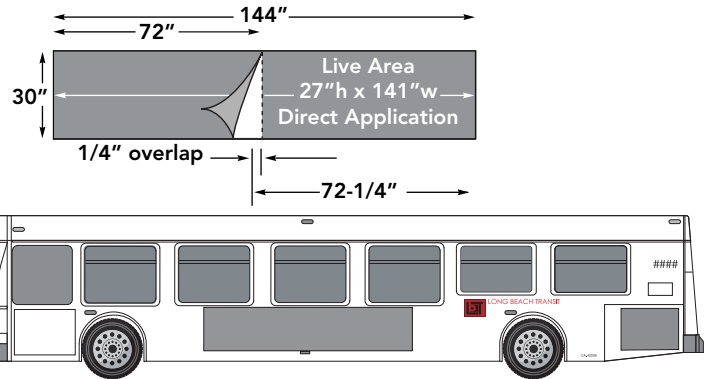

### SHIPPING ADDRESS

**Ship to** Outdoor Service Providers  
10601 Calle Lee, Suite 190  
Los Alamitos, CA 90720

**Phone** 714.229.0600 **Fax** 714.229.0660

**Contact** Oscar  
warehouse@collegebillboardnetwork.com

### DELIVERY

Titan Operations must receive materials 10 days prior to post date. Please include posting instructions and copy of creative with the poster shipment.